



NORTHERN EUROPE

Automator DK ApS (Denmark)
Vestergade 47 • DK-7100 Vejle
Tel. 0045-70200263 • Fax 0045-70200264
www.automator.com • E-mail: dk@automator.com

Automator UK (Great Britain)
48 Station Road • HARROW • Middlesex • HAI 2SQ
Tel. 020 8863 7141 & 6399 • Fax 020 8861 3658
www.automator.com • E-mail: uk@automator.com

CENTRAL EUROPE

PMS Präge + Markier Systeme AG (Switzerland)
Schönenhofstrasse 17, CH-8502 Frauenfeld
Tel. +41-(0)527250270 • Fax +41-(0)527250277
www.automator.com • E-mail: pms@automator.com

WESTERN EUROPE

Iberomark Mercado Industrial, SL (Spain)
Carretera Nova 127 • E-08530 La Garriga (Barcelona)
Tel. +34-938717095 • Fax +34-938717531
www.automator.com • E-Mail: clientes@automator.com

EASTERN EUROPE

Automator CZ, AS (Czech Republic)
Chrastavice 3, CZ-344 01 Domallice
Tel. +42 0189 8289 - 0189 8290 • Fax +42 0189 8290
www.automator.com • E-mail: cz@automator.com

SOUTHERN EUROPE

Automator Hellas (Greece)
P.O.Box 50772 • 54014 Thessaloniki
Tel. / Fax +30 31 438378
www.automator.com • E-mail: gr@automator.com

NORTH AMERICA

Markfirst Inc. (U.S.A.)
5763 Mining Terrace • Jacksonville 32257 Florida
Tel. +1-904-2921355 • Fax +1-904-2924920
www.automator.com • E-mail: usa@automator.com

SOUTH AMERICA

Central de Equipos Automaticos S.a. (Venezuela)
Urb. Los Cedros • Apt. 50062 • Sabana Grande
Caracas • Venezuela
Tel. +58-2-7311371 • Fax +58-2-7311369
www.automator.com • E-mail: yv@automator.com

OCEANIA

Nichol International Pty Ltd (Australia)
Terracotta Drive 50 • 3131 Nunawading Vic.
Tel. +61-3-98947788 • Fax +61-3-98947977
www.automator.com • E-mail: aa@automator.com

FAR EAST

Toyo Corporation (Japan)
Nakayamacho 5 Chome 10 • 00448 Aichi-ken Kariya Shi
Tel. +81 566 232011 • Fax +81 566 272221-231080
www.automator.com • E-mail: jp@automator.com



AUTOMATOR INTERNATIONAL s.r.l.
Via Meucci, 8 • I-20094 Corsico (Milano) - Italy
Tel. +39-0248601445 r.a. • Fax +39-0248601503
www.automator.com • E-Mail: info@automator.com

Specifications are subject to change without notice - VERSION 01



IMPACT PRJESSES

Standard Marking Systems Available Using Automator Technology

INDENT MARKING

Impact and roller marking guarantee clear, easily legible and permanent identification.

HOT MARKING

For materials such as leather, pelts, plastics, wood, paper, textiles etc; can also be used with interchangeable foils for marking in colour.

SAND JET MARKING

The pre-selected text is marked by a light abrasion of the top surface using micro-crystals. Particularly suitable for glass or metals which have already been heat treated.

COMPUTER CONTROLLED SINGLE DOT OR MULTI-DOT MARKING SYSTEMS

Linear, diagonal, arc or angular marking by indenting one or more styli into the surface of the part to be marked.

READING AND RECOGNITION

Identification by a camera and processing using specially written software.

MARKING OF NAMEPLATES

A large range of machines is available from manually operated models to highly sophisticated systems.

LASER MARKING

CO2 and YAG laser systems for marking of all types of material using the controlled movement of a focused laser beam.

ELECTROLYTIC MARKING

Suitable for marking hardened or shaped components. The marking unit imparts a controlled electrical impulse to the marking pad which leaves a permanent and indelible mark.

HYDRAULIC MARKING

Used for the portable marking of car bodies, profiles, tubes and beams.

DAISY WHEEL MARKING MACHINES

PC controlled marking units for marking silently and without deformation.

SPECIAL MACHINES

Designed and manufactured to meet specific requirements for marking, stamping and identification.

AUTOMATOR INTERNATIONAL presents its extensive range of standard and special machines for marking, stamping, identifying, punching, numbering, lettering etc. ... in other words for leaving an indelible and permanent mark on any surface or product whatsoever.

AUTOMATOR - WHO ARE WE

Impeccable quality and the highest technology are the basis for our ability to meet the most demanding and varied requirements of our customers, whatever branch of industry they may

come from.

The extensive range which constitutes the AUTOMATOR program provides the highest productivity using the latest production processes.



More than 50 years' experience guarantees that Automator will offer their customers an exclusive service to solve their particular marking problems.

Starting with interchangeable types and hand stamps, through mechanical and pneumatic machines, and finally



reaching the latest, most advanced and innovative computerised systems, Automator always takes a

leading role thanks to the very high

qualitative and technological standards it sets for itself in the international market place. Automator is also very well represented in emerging markets overseas and in the far east.



An extremely well trained and conscientious staff which is focused on progress and innovation to obtain the highest precision and quality for the product and for customer service is the corner-stone of Automator's success.

Reliability is for Automator the trademark which knows no frontiers.

The manually operated impact presses are available in 3 versions depending upon the maximum impact force required: 3 kN, 25 kN or 50 kN.

All machines offer following characteristics:

- The pre-clamping action of the press prevents material deformation
- Maximum sensitivity and accuracy
- Consistent depth of mark even for components with large variations in tolerance
- Exact pressure setting from 0 kN up to the maximum allowable for the model
- Easy accessibility for different sizes of component thanks to the large daylight
- High production rates
- Enormous range of accessories, such as types, typeholders, engraved dies, numbering heads, all of the highest quality (see pages 14/15)

Furthermore, the impact presses can be used for numerous applications apart from marking, such as riveting, assembling, inserting, press-fitting etc.

MANUAL IMPACT



Mod. MB 15



Mod. MB 20



Mod. MB 32

Technical Data:

	MB15	MB20	MB32
Impact range	3 kN (0-300 kg)	25 kN (0-2500 kg)	50 kN (0-5000 kg)
Daylight (max)	0-260 mm	0-323 mm	0-390 mm
Nett weight	10 kg	33 kg	99 kg
Table size	102x102 mm	162x162 mm	224x224 mm
Spigot size	Ø6x30 mm Ø8x32 mm	Ø10x38 mm	Ø16x48 mm
T-nut (DIN 650)	6 mm	8 mm	12 mm
Overall stroke	35 mm	61 mm	106 mm
Pre-travel	10 mm	18 mm	22 mm
Useable stroke	0-25 mm	0-43 mm	0-84 mm

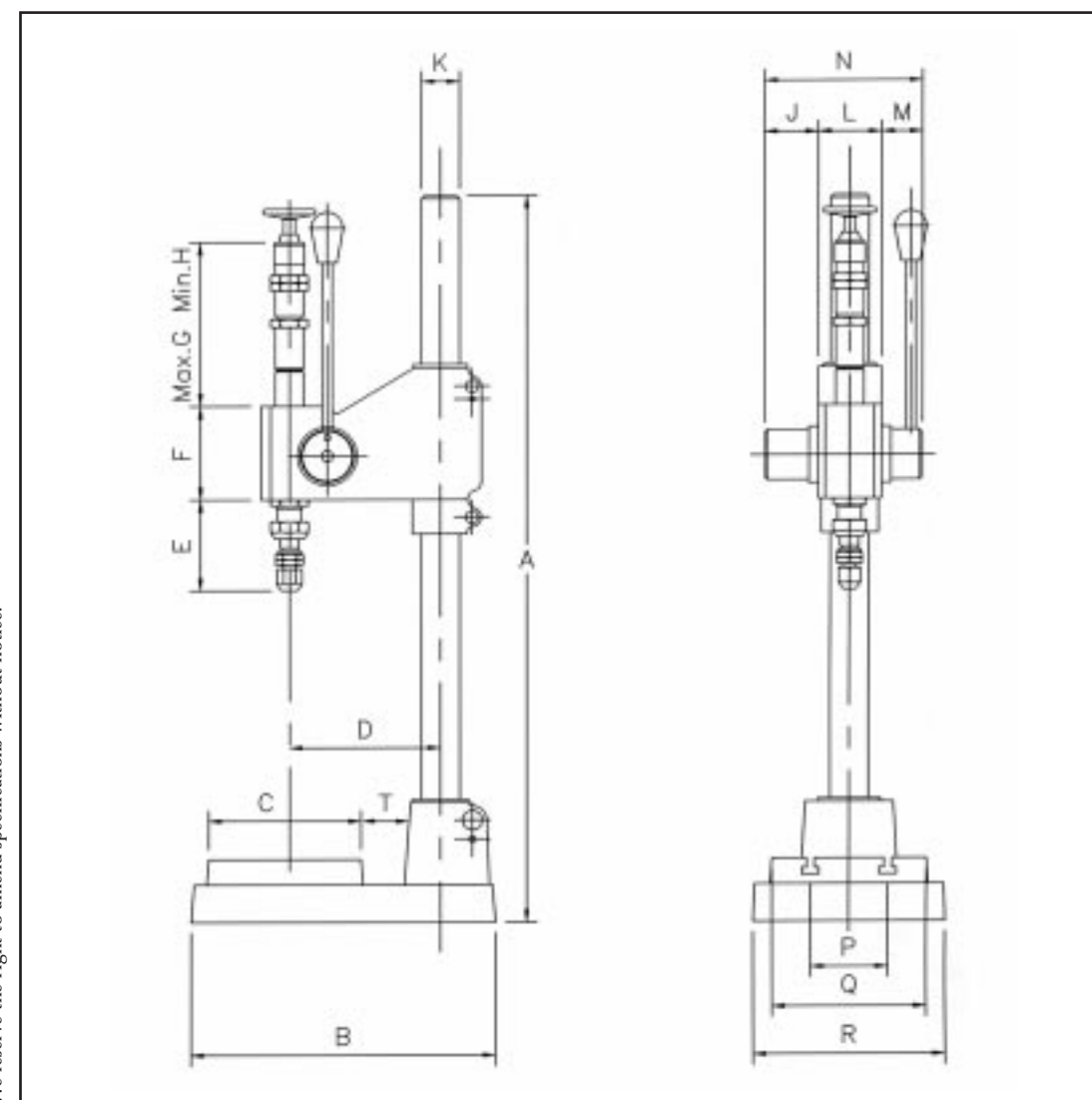

We reserve the right to amend specifications without notice.

Dimensions (mm):

	A	B	C	D	E	F	G	H	K	J	L	M	N	P	Q	R	T
MB15	454	215	102	112	48	58	130	100	30	28	48	30	106	50	102	130	40
MB20	653	316	162	160	115	102	190	160	42	56	65	44	165	80	162	203	50
MB32	858	445	224	230	155	181	340	320	70	66	106	59	231	120	224	280	70

The pneumatic impact presses are available in 3 versions depending upon the maximum impact force required: 3 kN, 25 kN and 50 kN. All machines offer the following characteristics:

- The pre-clamping action of the press prevents material deformation
- Maximum sensitivity and accuracy
- Consistent depth of mark even for components with large variations in tolerance
- Exact pressure setting from 0 kN up to maximum allowable for the model
- Easy accessibility for different sizes of component thanks to the large daylight
- Double acting pneumatic cylinders increase operating speeds
- Simple integration into production lines
- Enormous range of accessories, such as types, typeholders, engraved dies, numbering heads, all of the highest quality (see pages 14/15)

Furthermore, the impact presses can be used for numerous applications apart from marking, such as riveting, assembling, inserting, press-fitting etc.

PNEUMATIC IMPACT

Mod. MB 19



Mod. MB 21



Mod. MB 35



Technical Data:

	MB19	MB21	MB35
Impact range	3 kN (0-300 kg)	25 kN (0-2500 kg)	50 kN (0-5000 kg)
Throat height (max)	0-175 mm	0-265 mm	0-300 mm
Nett weight	14,5 kg	53 kg	162 kg
Air connection	1/8	1/4	3/8
Spigot size	Ø6x30 mm Ø8x32 mm	Ø10x38 mm	Ø16x48 mm
T-nut (DIN 650)	6 mm	8 mm	12 mm
Overall stroke	22 mm	60 mm	80 mm
Pre-travel	8 mm	18 mm	22 mm
Useable stroke	0-14 mm	0-42 mm	0-58 mm
Air pressure (max)	10 bar	10 bar	10 bar
Air consumption per stroke	0,183 dm ³ (a 4 bar)	1,049 dm ³ (a 6 bar)	1,668 dm ³ (a 6 bar)

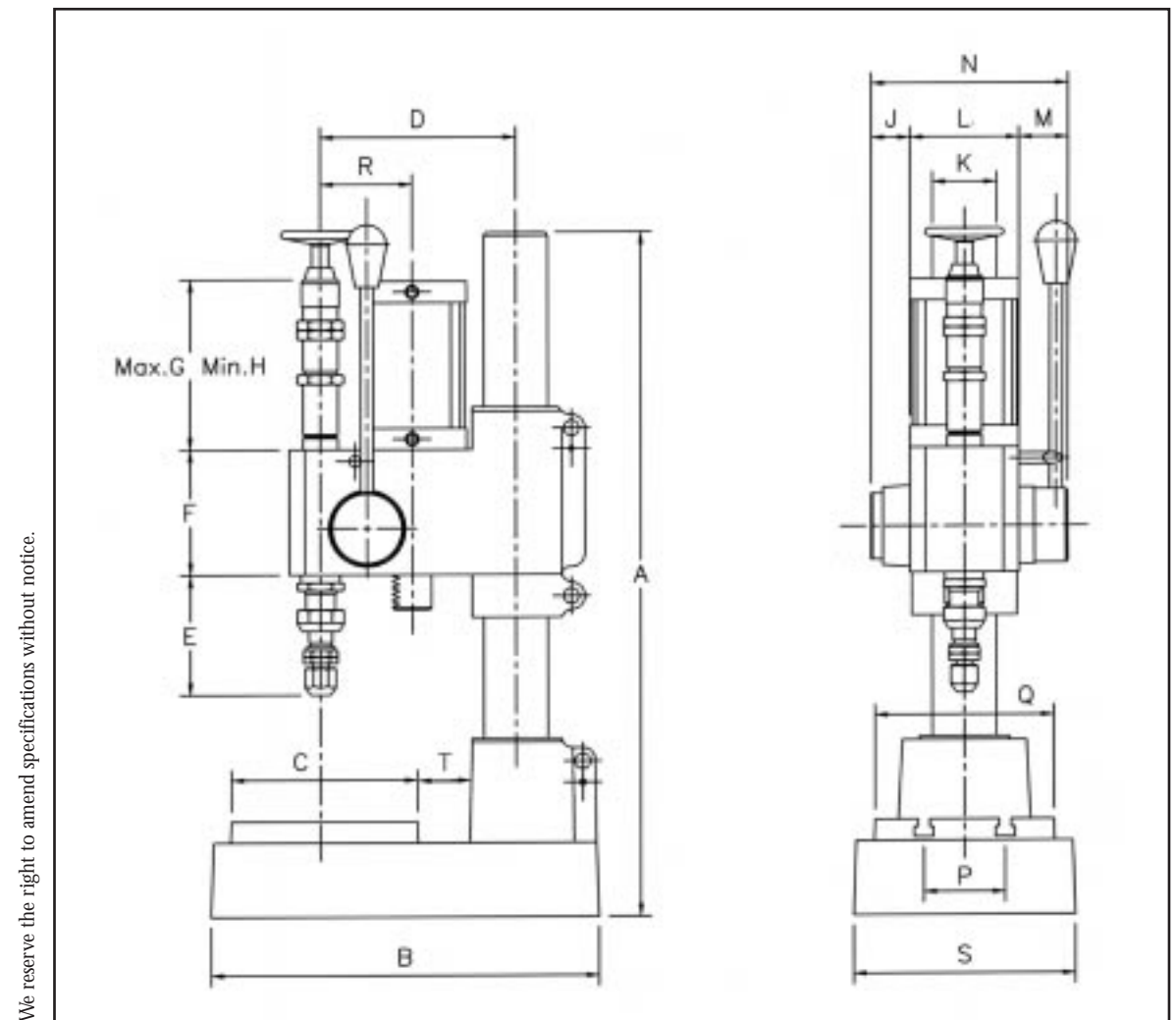

Dimensions (mm):

	A	B	C	D	E	F	G	H	K	J	L	M	N	P	Q	R	S	T
MB19	375	225	110	112,5	48	67	121	91	36	22	58	30	110	50	110	170	240	30
MB21	630	360	170	180	120	116	162	132	60	38	102	45	185	80	170	85	200	50
MB35	840	503	240	260	155	180	340	320	100	40	170	52	262	120	240	112	300	70

The impact units of the VP series are available in 3 versions depending upon the maximum impact force required: 3 kN, 25 kN and 50 kN. All machines offer the following characteristics:

- The pre-clamping action of the press prevents material deformation
- Maximum sensitivity and accuracy
- Consistent depth of mark even for components with large variations in tolerance
- Exact pressure setting from 0 kN up to maximum allowable for the model
- Very compact design
- Double acting cylinders increase operating speeds
- Especially suitable for integration in transfer lines
- Suitable for mounting in any plane
- Impact can be released at any point within the stroke
- Enormous range of accessories, such as types, typeholders, engraved dies, numbering heads, all of the highest quality (see pages 14/15)

Furthermore, the impact presses can be used for numerous applications apart from marking, such as riveting, assembling, inserting, press-fitting etc.

IMPACT UNITS



Mod. MB 21 VP



Mod. MB 19 VP

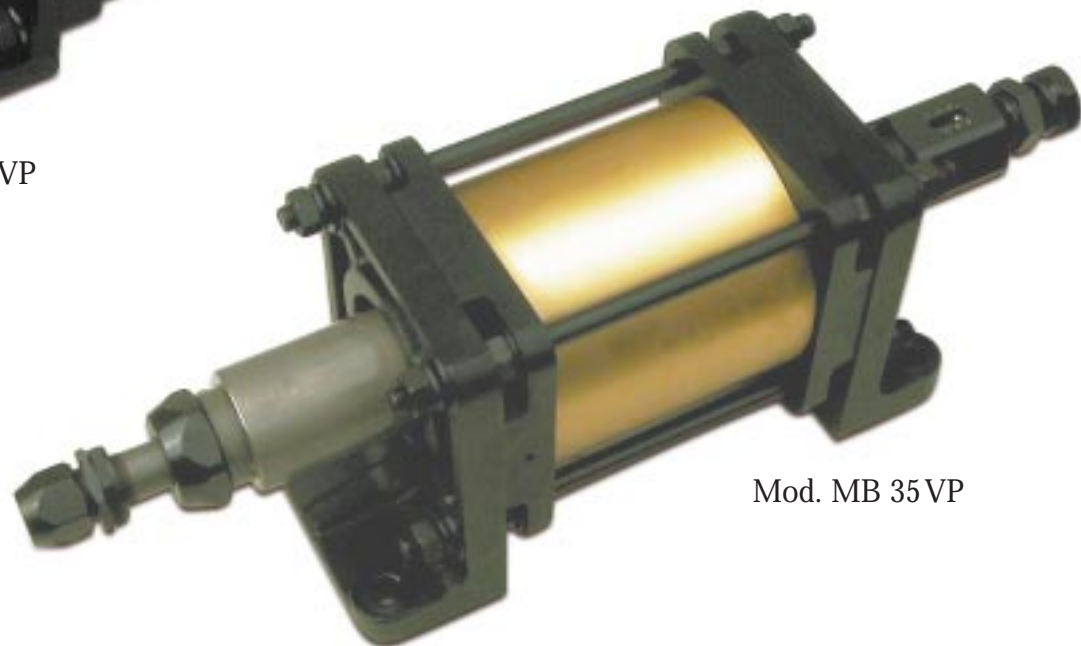

Mod. MB 35 VP

Technical Data:

	MB19VP	MB21VP	MB35VP
Impact range	3 kN (0-300 kg)	25 kN (0-2500 kg)	50 kN (0-5000 kg)
Nett weight	2 kg	10 kg	38 kg
Air connection	1/8	1/4	3/8
Spigot size	Ø6x30 mm Ø8x32 mm	Ø10x38 mm	Ø16x48 mm
Overall stroke	32 mm	67 mm	110 mm
Pre-travel	8 mm	18 mm	25 mm
Useable stroke	0-24 mm	0-49 mm	0-85 mm
Air pressure (max)	10 bar	10 bar	10 bar
Air consumption per stroke	0,22 dm ³ (a 4 bar)	1,049 dm ³ (a 6 bar)	2,726 dm ³ (a 6 bar)

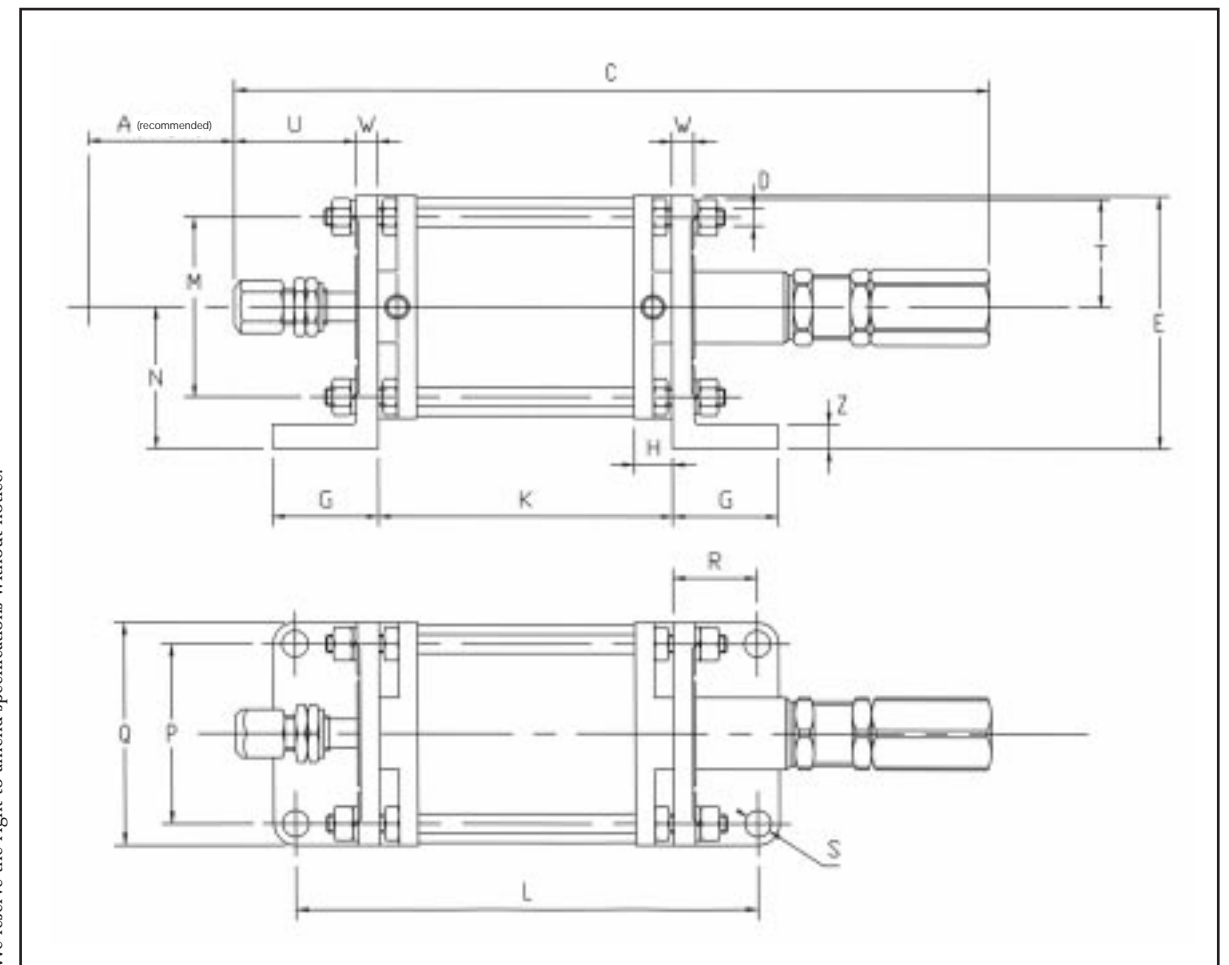

We reserve the right to amend specifications without notice.

Dimensions (mm):

	A	C	D	E	G	H	K	L	M	N	P	Q	R	S	T	U	W	Z
MB19VP	48	260	M8	78	45	14	88	158	50	45	45	65	35	10,5	32,5	45	10	10
MB21VP	88	407	M10	130	55	20	151	238	90	73	90	115	43	14	73	65	12	12
MB35VP	105	841	M16	216	86	30	232	268	140	125	140	180	66	17	92	134	27	25

The impact spindles are available in 3 versions depending upon the maximum impact force required: 3 kN, 25 kN or 50 kN.

All spindles offer the following characteristics:

- The pre-clamping action of the press prevents material deformation
- Maximum sensitivity and accuracy
- Consistent depth of mark even for components with large variations in tolerance
- Exact pressure setting from 0 kN up to maximum allowable for the model
- Extremely compact dimensions
- Capable of being mounted on a fixture with double acting cylinder
- Particularly suited for integration in transfer lines and capable of being mounted in any plane
- Enormous range of accessories, such as types, typeholders, engraved dies, numbering heads, all of the highest quality (see pages 14/15)

Furthermore, the impact presses can be used for numerous applications apart from marking, such as riveting, assembling, inserting, press-fitting etc.

IMPACT SPINDLES



MB15/19



MB20/21



MB32/35

Technical Data:

	MB15/19	MB20/21	MB32/35
Impact range	3 kN (0-300 kg)	25 kN (0-2500 kg)	50 kN (0-5000 kg)
Nett weight	0,6 kg	2,1 kg	10,2 kg
Spigot size	Ø6x30 mm Ø8x32 mm	Ø10x38 mm	Ø16x48 mm
Overall stroke	35 mm	61 mm	106 mm
Pre-travel	10 mm	18 mm	22 mm
Useable stroke	0-25 mm	0-43 mm	0-84 mm

We reserve the right to amend specifications without notice.

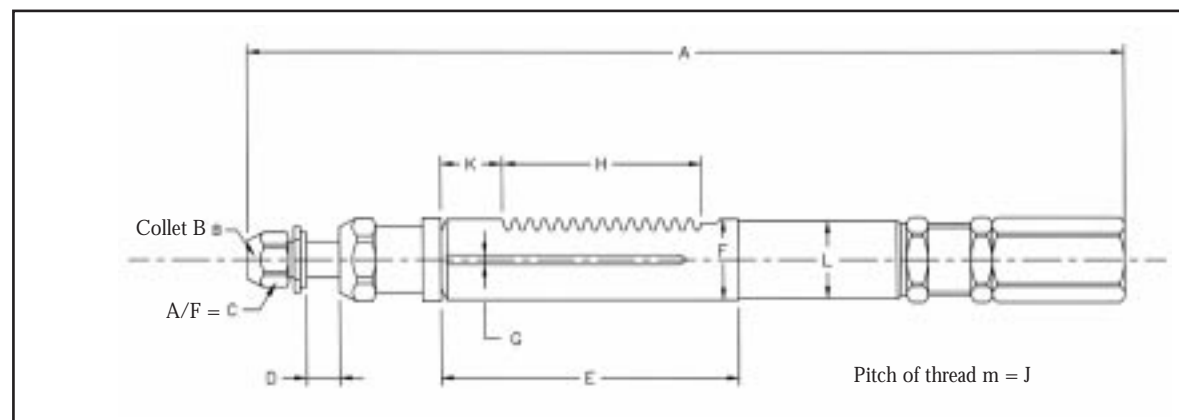

Dimensions (mm):

	A	B	C	D	E	F	G	H	K	J	L
MB15	240	Ø6-8	13-17	8	80	25	3	54	15	1,25	24
MB20	400	Ø10	24	17	137	36	6	97	19	2	34
MB32	670	Ø16	36	22	246	60	7	136	80	2	58

MICRO CENTRE PUNCH

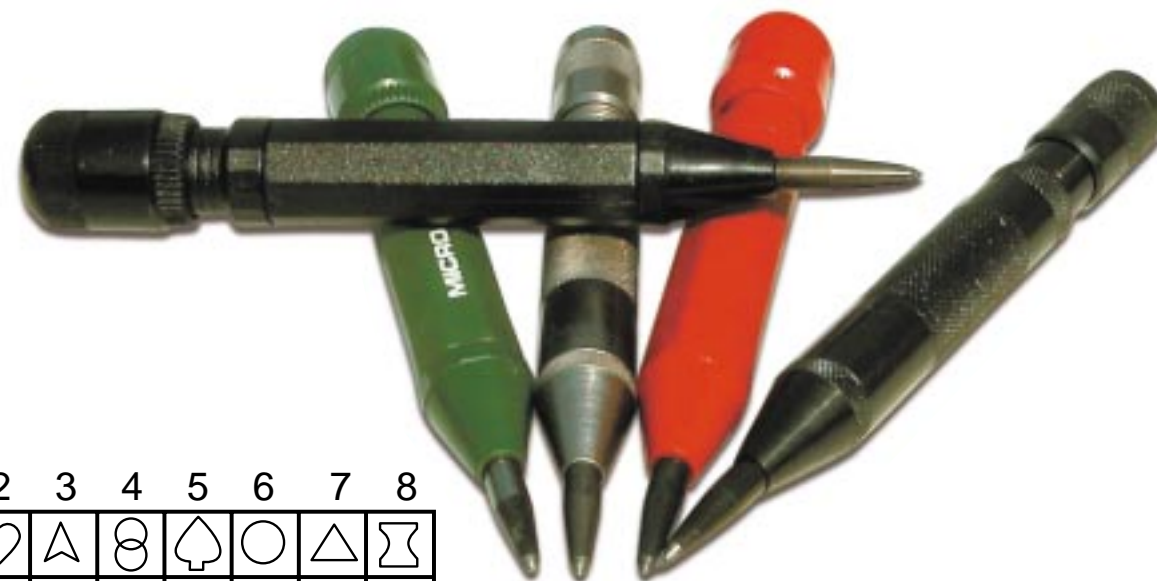

	1	2	3	4	5	6	7	8
A	□	♥	△	∞	♠	○	△	⊗
B	⊞	⊞	⊞	⊞	⊞	⊞	⊞	⊞
C	⊞	⊞	⊞	⊞	⊞	⊞	⊞	⊞
D	⊞	⊞	⊞	⊞	⊞	⊞	⊞	⊞
E	⊞	⊞	⊞	⊞	⊞	⊞	⊞	⊞
F	⊞	⊞	⊞	⊞	⊞	⊞	⊞	⊞
G	⊞	⊞	⊞	⊞	⊞	⊞	⊞	⊞

Table of special marking symbols

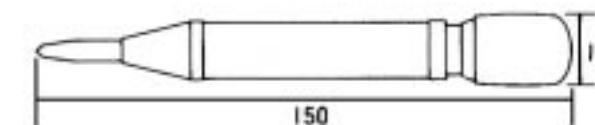

MICRO CENTRE PUNCH

Portable marking unit. The internal impact force is triggered by pressure using the palm of the hand. The micro centre punch is practical, versatile and quick, and has an impact force adjustable from 5-50 kg. The micro centre punch is available in black metal or in coloured plastic. Various punches are available including letters of the alphabet, numbers in 2.5 mm. height as well as the symbols shown in the adjacent table. Special signs and logos can also be supplied on request up to a maximum of 3 mm height.



TWIN PUSH BUTTON SAFETY CONTROL SYSTEM

Technical data:

- Filtered air either lubricated or not lubricated
- Air pressure: 2-8 bar
- Temperature range: min -10°/max 60°C

Pneumatic Elements:

- ① Pneumatic valve 5/2 way - pneumatically operated
- ② Safety valve
- ③ Protected push buttons



Automator offers 2 different twin push button safety systems:

Security 1 is a twin push button safety control system to CE standards

Security 2 is a twin push button safety control system to CE standards with an additional adjustable timer fitted to the front panel. This is particularly useful for hot marking as this can set the dwell time for the marking head.

DECLARATION OF CONFORMITY

Automator International Srl • Via Meucci 8 • I-20094 Corsico (MI) declares that the twin push button safety control system Type Security 1 Code 08.156.4 conforms to the following **CE** norms: CE 89/392, 91/368, 93/44, 93/68 and has acquired the following registration number:

nr. 0249 AT 261

on 30.07.1996 from the Institute ANCPP Srl and registered with the Italian Ministry of Industry under no. 0302.

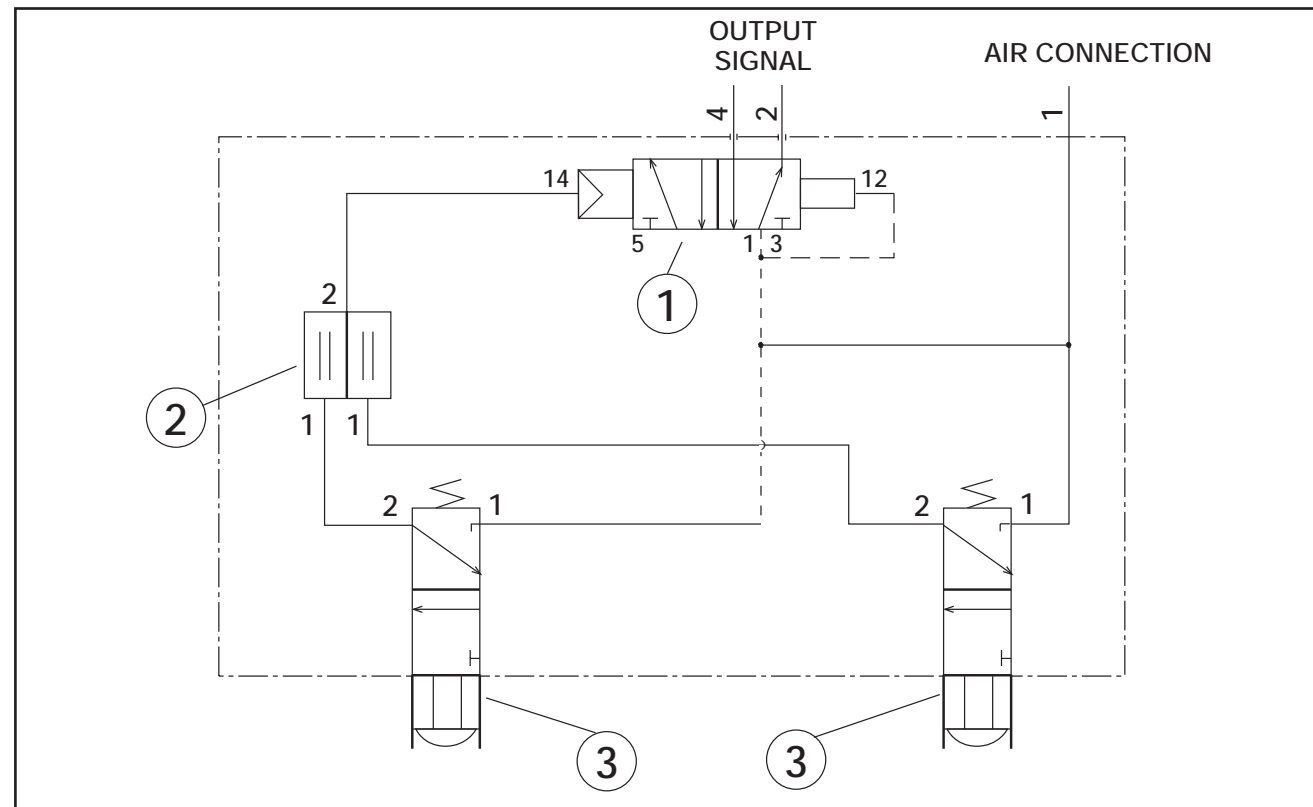

SPECIAL APPLICATIONS



MARKING OF HOT MELT HEADS

In a marking cycle the following data is marked:

- Manufacturers name
- Electrical current
- Sequential serial number using the MB2 numbering head

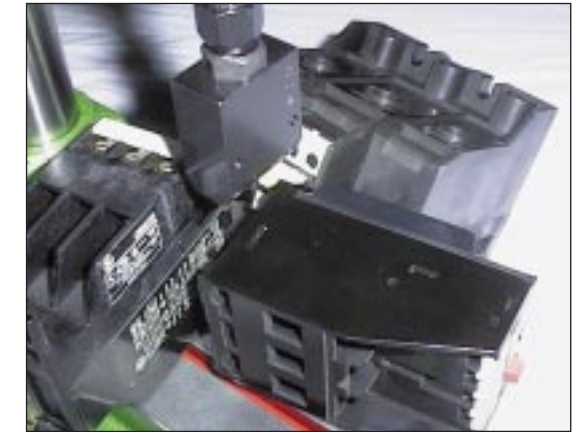

MARKING OF ELECTRO MECHANICAL COMPONENTS

Marking of electro mechanical components with information such as electrical current, serial number, batch number. All in one operation, which means marking time of a fraction of a second and minimum costs.

SPECIAL APPLICATION WITH IMPACT UNITS

Special equipment for the marking of hexagonal valve bodies consisting of 6 units MB21VP with the possibility of marking from 2 to 6 sides simultaneously.

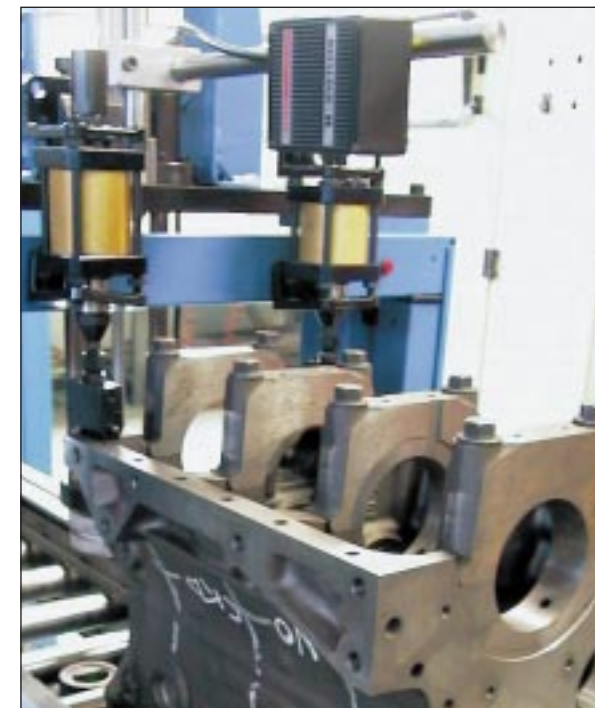

MARKING OF ENGINE BLOCKS

Two compact impact units in an automatic production line mark the two sides of an engine block simultaneously. This is required for subsequent assembly purposes.



MARKING OF WOODEN PROFILE

The individual components for doors and windows are marked to simplify later assembly. The batch number and order number are marked.

ACCESSORIES



FONT SETS

Automator steel types are of exceptional quality, incorporating as they do 50 years' experience. They are made from specially selected steel, which guarantees a long life time.

The most modern production methods ensures perfect centering and exact dimensional tolerances. Standard font sets with or without a typeholder contain:

- 100 characters
- 20 blanks
- Tweezers and allen key



- Types of characters:
- standard sharp face
 - multi-dot
 - rounded
 - flat face
 - hot marking
 - lower case

Height of standard character sizes

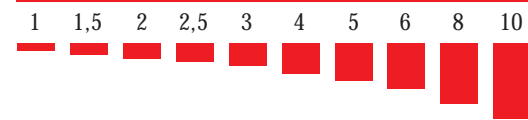

ENGRAVED STAMPS & DIES

Special dies and punches to any shape with perfect representation of logos or script are made to customers' requirements from special steel. Many years of experience guarantees highest quality and closest tolerances.



BANCHES



Model T:
Adjustable table height from 700-790 mm.
Adjustable foot-rest suitable for MB15/19/20/21/32/40N

Model TG
Compact frame with either laminated plastic or steel top plate 500x600 mm suitable for MB32/35/71N/71E/71CE

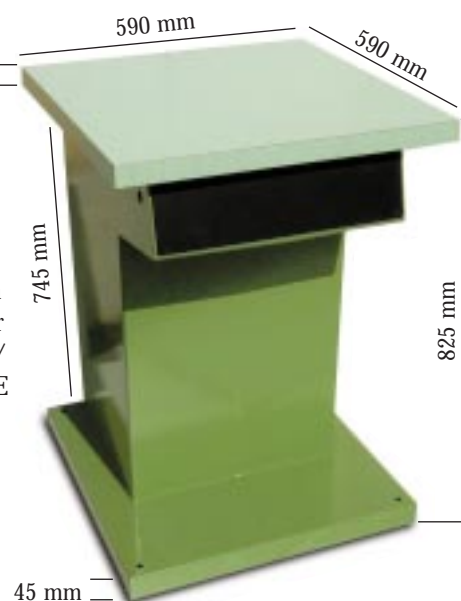

TYPEHOLDERS

An enormous range of typeholders of both standard and special design is available to resolve any marking application. The linear 1, 2 and 3 line typeholders as well as the circular typeholders all are provided with a tapped hole at the rear to take the required spigot. Because of this feature Automator typeholders can be mounted on any model of impact press or roller marking machine.



A mano



Ø 16



Ø 10



Ø 8



Ø 6

SPIGOTS

The various sizes of spigot serve to attach dies, punches, typeholders, numbering heads, etc to the appropriate marking machine. Hand held spigots are offered when you wish to mark using a hammer.

NUMBERING HEADS

These are ideal for marking of frequently changing numbers or sequentially incrementing serial numbers; a numbering head can be supplied for every character size and shape of component. Special numbering heads with spacer wheels, slots for holding interchangeable steel types etc. can be supplied on request. Available as two models:

- MB2 automatic
- MB14 manual

Height of standard character sizes

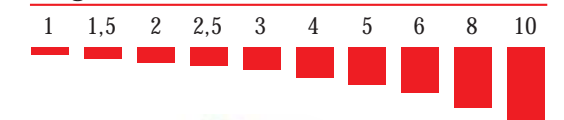

MB 2



MB 14